

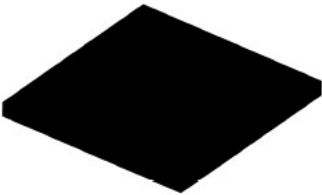



7 MISCELLANEOUS ITEMS			
7.1	<p>T-MI-001 3mm THICK LOW FRICTION ISOLATING PAD (-) 46 °c TO (+) 150 °c</p> 	7.4	<p>T- MI-004 3mm THICK ISOLATING PAD (-) 46 °c TO (+) 150 °c</p> 
7.2	<p>T-MI-002 6mm THICK LOW FRICTION ISOLATING PAD (-) 46 °c TO (+) 150 °c</p> 	7.5	<p>T-MI-005 LOW FRICTION SLIDE UNIT (-) 46 °c TO (+) 150 °c</p> 
7.3	<p>T-MI-003 6mm THICK LOW FRICTION ISOLATING PAD WITH STAINLESS STEEL PLATE (-) 46 °c TO (+) 150 °c</p> 	7.6	<p>T-MI-006 GRIP CLAMP LINING STRIP (-) 46 °c TO (+) 150 °c</p> 

7 MISCELLANEOUS ITEMS

7.7 T-MI-007
NON-GRIP CLAMP LINING STRIP
 (-) 46 °c TO (+) 150 °c

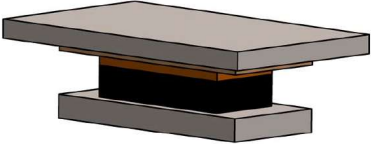

7.10 T-MI-010
HIGH TEMPERATURE
GRIP CLAMP LINING STRIP
 (-) 46 °c TO (+) 300 °c

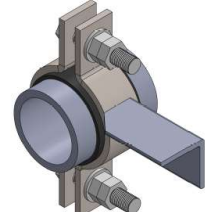

7.8 T-MI-008
NON-GRIP CLAMP LINING STRIP
 (-) 46 °c TO (+) 150 °c



7.11 T-MI-011
LOW TEMPERATURE
GRIP CLAMP LINING STRIP
 (-) 100 °c TO (+) 150 °c

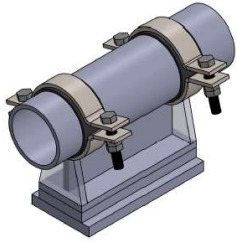

7.9 T-MI-009
HIGH TEMPERATURE
GRIP CLAMP LINING STRIP
 (-) 60 °c TO (+) 350 °c



7.12 T-MI-012
LOW TEMPERATURE
GRIP CLAMP LINING STRIP
 (-) 100 °c TO (+) 250 °c

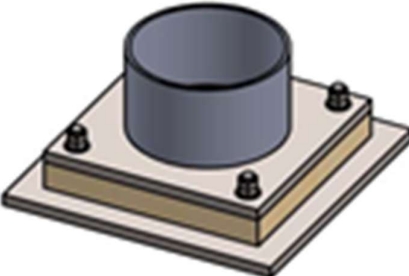

7	MISCELLANEOUS ITEMS
----------	----------------------------

7.13	<p>T-MI-020 COLD BLOCKS FOR VERTICAL TRUNNIONS</p> 			
-------------	---	--	--	--

--	--	--	--	--

--	--	--	--	--

--	--	--	--	--

7.1 3mm THICK LOW FRICTION ISOLATING PAD
 (-) 46 °c TO (+) 150 °c

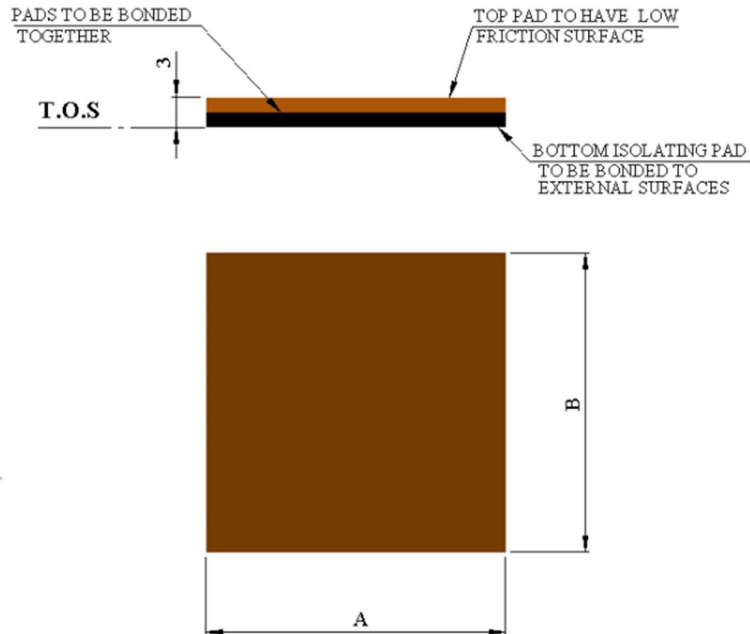
MI-001

TYPE	A	B
T-MI-001-000A	50	25
T-MI-001-000B	100	50
T-MI-001-000C	150	100
T-MI-001-000D	200	200
T-MI-001-000E	250	250
T-MI-001-000F	300	300

All surfaces should be thoroughly cleaned before bonding.
 Isolating pad material: ASEplas SW622.
 Design temperature range (-)46°c to (+) 150°c.

7.2 6mm THICK LOW FRICTION ISOLATING PAD
 (-) 46 °c TO (+) 150 °c

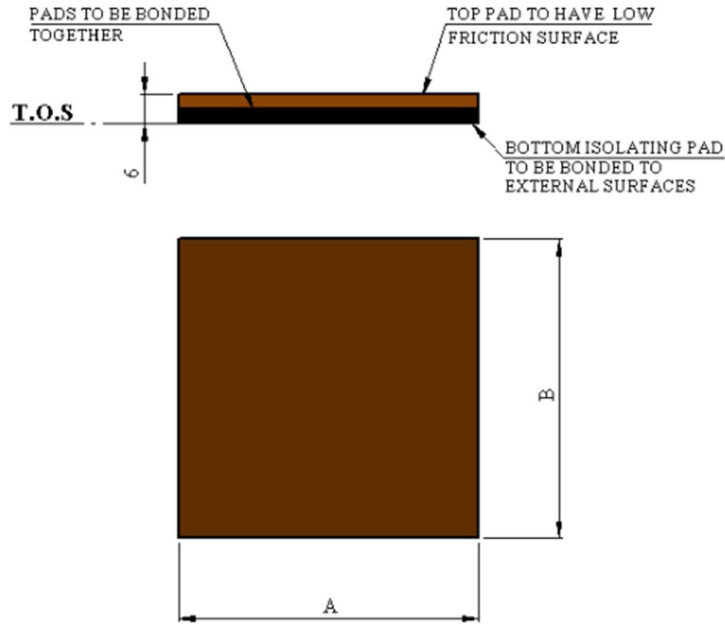
MI-002

TYPE	A	B
T-MI-002-000A	50	25
T-MI-002-000B	100	50
T-MI-002-000C	150	100
T-MI-002-000D	200	200
T-MI-002-000E	250	250
T-MI-002-000F	300	300

All surfaces should be thoroughly cleaned before bonding.
 Isolating Pad material: ASEplas SW622
 Design temperature range (-)46°C to (+)150°C.

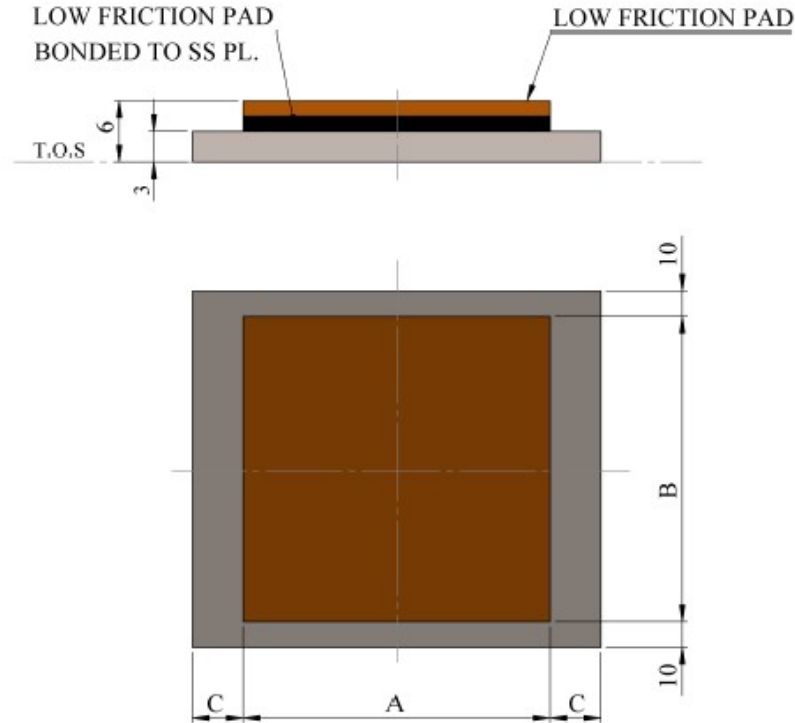
7.3 6mm THICK LOW FRICTION ISOLATING PAD WITH STAINLESS STEEL PLATE (-) 46 °c TO (+) 150 °c
MI-003

TYPE	A	B	C
T-MI-003-000A	50	25	15
T-MI-003-000B	100	50	25
T-MI-003-000C	150	100	25
T-MI-003-000D	200	200	25
T-MI-003-000E	250	250	25
T-MI-003-000F	300	300	25

All surfaces should be thoroughly cleaned before all welding or bonding.
 Isolating pad material: ASEplas SW622.
 Stainless steel baseplates to be tack welded to pipe support structure. Alternatively, baseplate can be bonded to pipe support structure with a project approved Adhesive.
 Design temperature range (-)46°c to (+) 150°c.

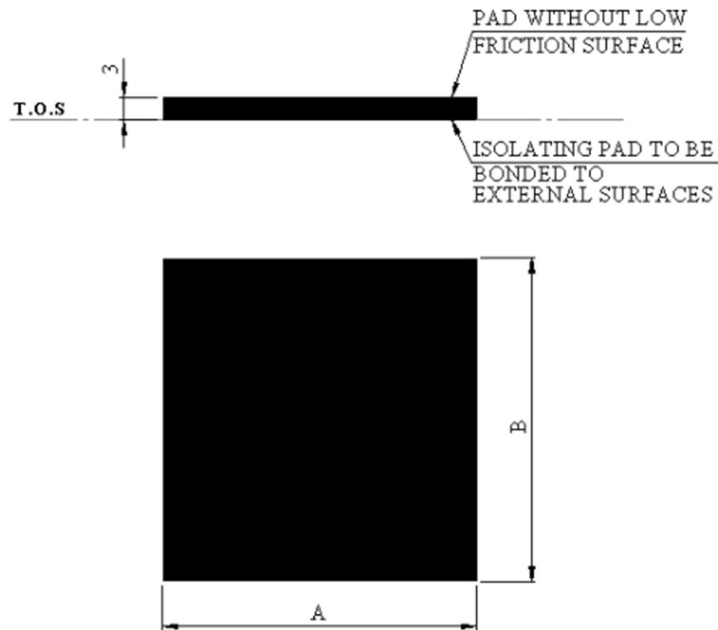
7.4 3mm THICK ISOLATING PAD (-) 46 °c TO (+) 150 °c
MI-004

TYPE	A	B
T-MI-004-000A	50	25
T-MI-004-000B	100	50
T-MI-004-000C	150	100
T-MI-004-000D	200	200
T-MI-004-000E	250	250
T-MI-004-000F	300	300

All surfaces should be thoroughly cleaned before bonding.
 Isolating pad material: ASEplas SW150.
 Design temperature range (-)46°C to (+) 150°C

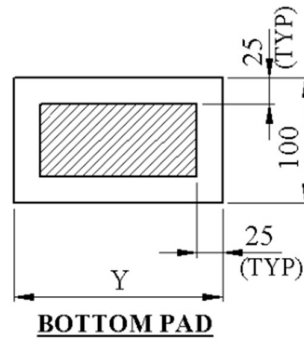
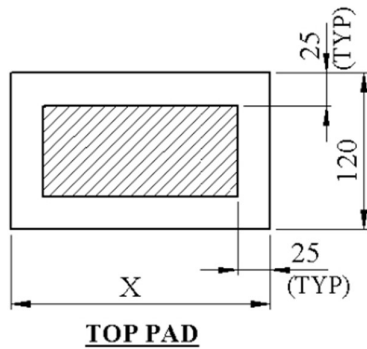
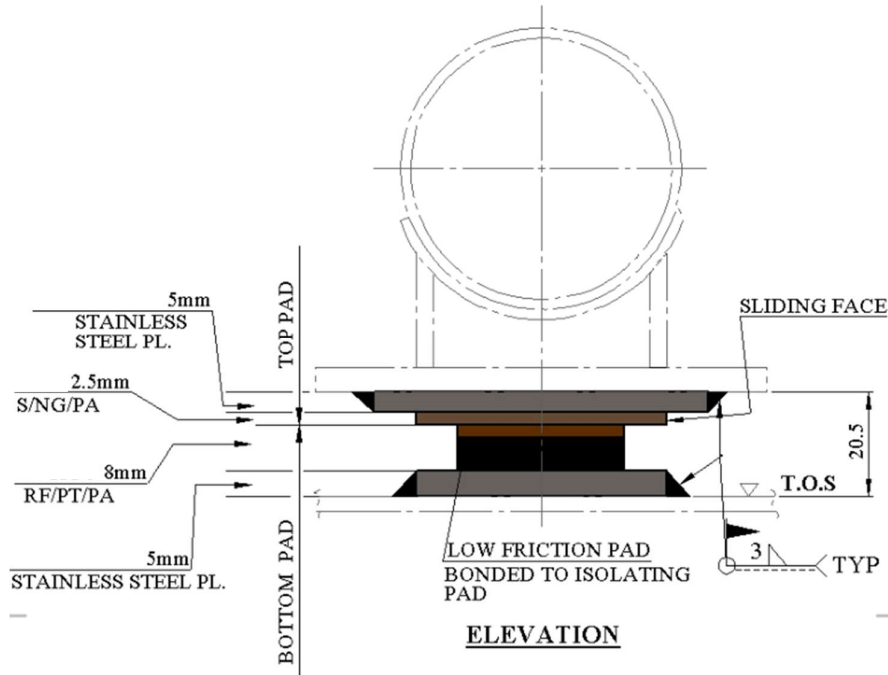
7.5 LOW FRICTION SLIDE UNIT (-) 46 °c TO (+) 150 °c
MI-005

TYPE	X	Y	LOAD RANGE (kN)
T-MI-005-000A	150	100	17.5
T-MI-005-000B	175	125	26
T-MI-005-000C	200	150	35
T-MI-005-000D	225	175	44

All surfaces should be thoroughly cleaned before all welding or bonding.
 Stainless steel baseplates to be tack welded to pipe support structure. Alternatively, baseplate can be bonded to pipe support structure with a project approved Adhesive.
 Design temperature range (-)46°C to (+) 150°C.
 Coefficient of Friction = 0,1
 Load Range = 7 MPa
 Isolation Materials
 S/NG/PA: ASEplas SW834
 RF/PT/PA: ASEplas SW619

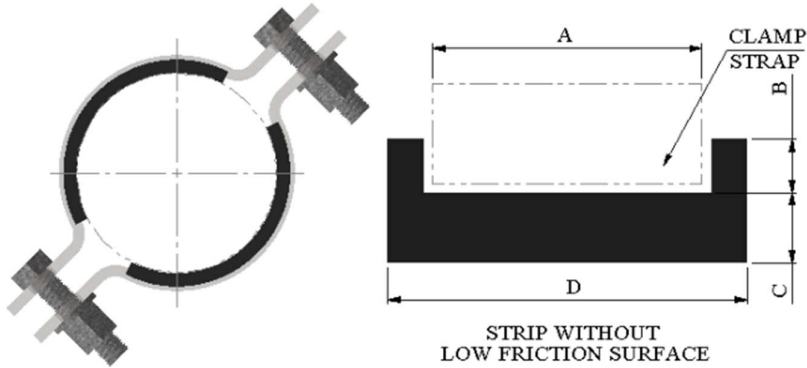
7.6 GRIP CLAMP LINING STRIP (-) 46 °c TO (+) 150 °c
MI-006

TYPE	A	B	C	D
T-MI-006-000A	25	2	3	35
T-MI-006-000B	30	2	3	40
T-MI-006-000C	40	2	3	50
T-MI-006-000D	45	2	3	55
T-MI-006-000E	50	2	3	60
T-MI-006-000F	60	2	3	70
T-MI-006-000G	65	2	3	80
T-MI-006-000H	70	2	3	85
T-MI-006-000I	75	2	3	90
T-MI-006-000J	80	2	3	95
T-MI-006-000K	90	2	3	105
T-MI-006-000L	100	2	3	115
T-MI-006-000M	110	3	3	125
T-MI-006-000N	130	3	3	145
T-MI-006-000O	140	3	3	155
T-MI-006-000P	150	3	3	165
T-MI-006-000Q	200	3	3	215

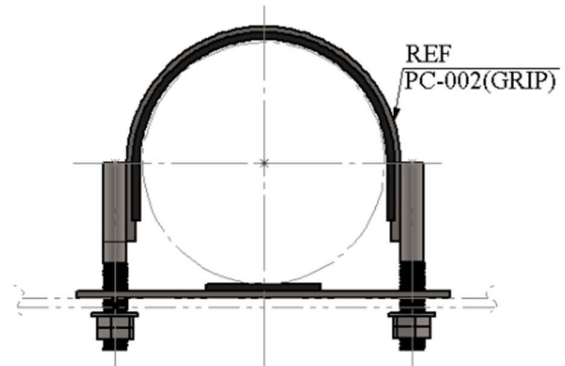

All surfaces should be thoroughly cleaned before bonding.
 Clamp lining strip material: ASEplas SW150
 Design temperature range (-)46°C to (+)150°C.

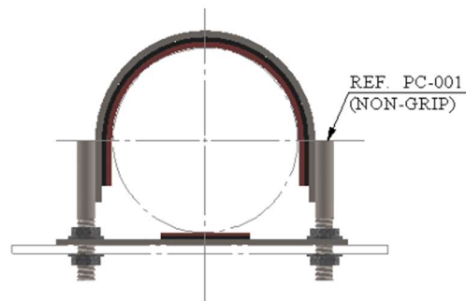
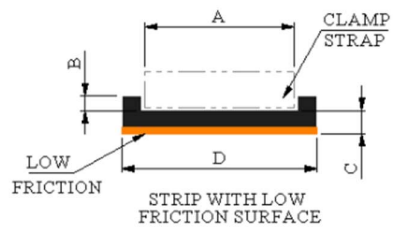
7.7 NON-GRIP CLAMP LINING STRIP (-) 46 °c TO (+) 150 °c
MI-007

TYPE	A	B	C	D
T-MI-007-000A	25	2	4	35
T-MI-007-000B	30	2	4	40
T-MI-007-000C	40	2	4	50
T-MI-007-000D	45	2	4	55
T-MI-007-000E	50	2	4	60
T-MI-007-000F	60	2	4	70
T-MI-007-000G	65	2	4	80
T-MI-007-000H	70	2	4	85
T-MI-007-000I	75	2	4	90
T-MI-007-000J	80	2	4	95
T-MI-007-000K	90	2	4	105
T-MI-007-000L	100	2	4	115
T-MI-007-000M	110	3	4	125
T-MI-007-000N	130	3	4	145
T-MI-007-000O	140	3	4	155
T-MI-007-000P	150	3	4	165
T-MI-007-000Q	200	3	4	215

All surfaces should be thoroughly cleaned before bonding
 Design temperature range (-)46°C to (+) 150°
 Clamp lining strip material: ASEplas SW622.

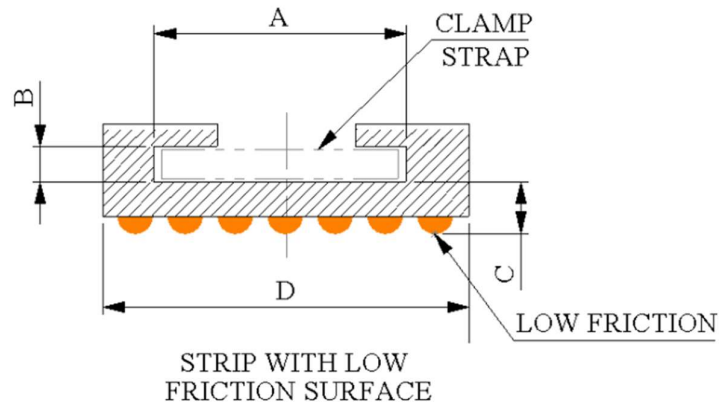
7.8 NON-GRIP CLAMP LINING STRIP (-) 46 °c TO (+) 150 °c
MI-008

TYPE	A	B	C	D
T-MI-008-000A	50	6	3	55
T-MI-008-000B	60	10	3	65
T-MI-008-000C	70	12	3	75
T-MI-008-000D	100	12	3	105

Design temperature range (-)46°C to (+) 150°C
 Only to be used on PC-001 in Stainless Steel material.
 Isolation Pad Material: ASEplas SW150

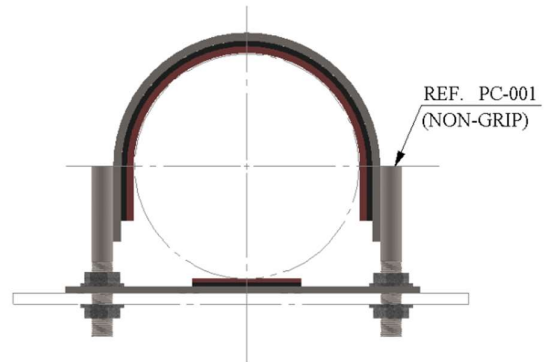

7.9 HIGH TEMPERATURE GRIP CLAMP LINING STRIP
 (-) 60 °c TO (+) 350 °c

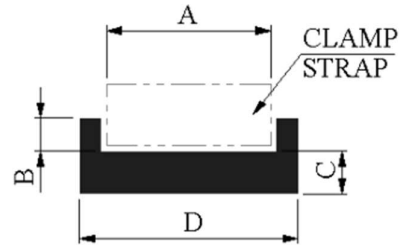
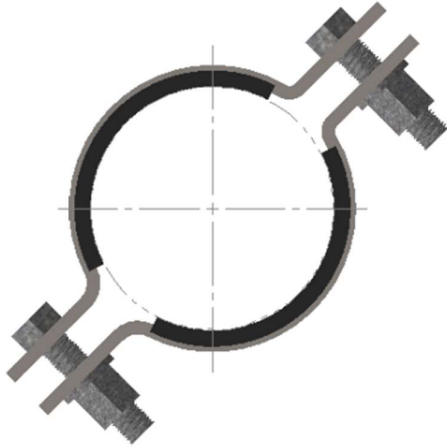
MI-009

TYPE	A	B	C	D
T-MI-009-000A	25	2	3	40
T-MI-009-000B	30	2	3	50
T-MI-009-000C	40	2	3	55
T-MI-009-000D	45	2	3	60
T-MI-009-000E	50	2	3	70
T-MI-009-000F	60	2	3	80
T-MI-009-000G	65	2	3	85
T-MI-009-000H	70	2	3	90
T-MI-009-000I	75	2	3	95
T-MI-009-000J	80	3	3	105
T-MI-009-000K	90	3	3	115
T-MI-009-000L	100	3	3	125
T-MI-009-000M	110	3	3	145
T-MI-009-000N	130	3	3	155
T-MI-009-000O	140	3	3	165
T-MI-009-000P	150	3	3	165
T-MI-009-000Q	200	3	3	215

 Design temperature range (-)60°C to (+)350°C
 Clamp lining strip material: ASEplus SW705

7.10 HIGH TEMPERATURE GRIP CLAMP LINING STRIP
 (-) 46 °c TO (+) 300 °c

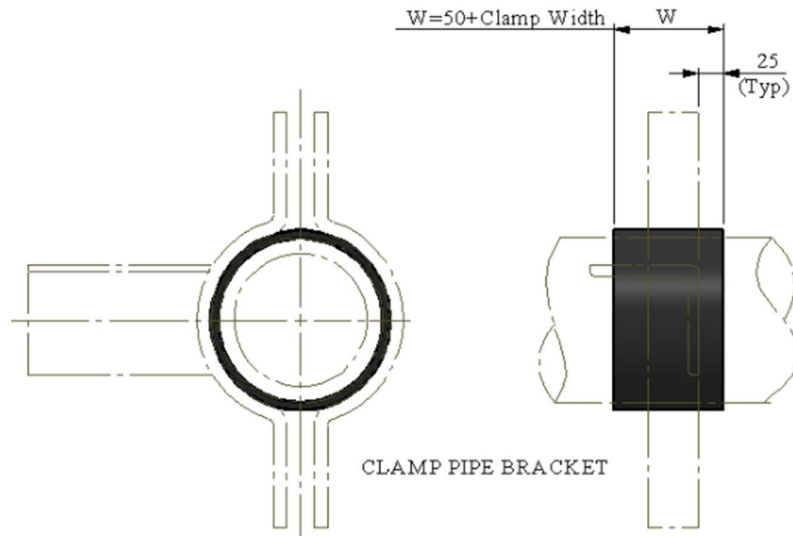
MI-010

CLAMP PIPE BRACKET

*MI-010 SHALL ONLY BE USED FOR GRIP
 TYPE SMALL BORE PIPE CLAMP BRACKETS
 PC-025, PC-026 & PC-027.

PC-025 & PC-026. Wrap around the pipe to make up 3mm thickness.
 PC-027 Wrap around the pipe to make up 1.5mm Thickness.
 Design temperature range (-)46°c to (+) 300°c
 No bonding required.
 High Temperature tape material and manufacturers shall be subject to project approval.
 Clamp lining strip material: ASEplas SW705

7.11 LOW TEMPERATURE GRIP CLAMP LINING STRIP
 (-) 100 °c TO (+) 150 °c

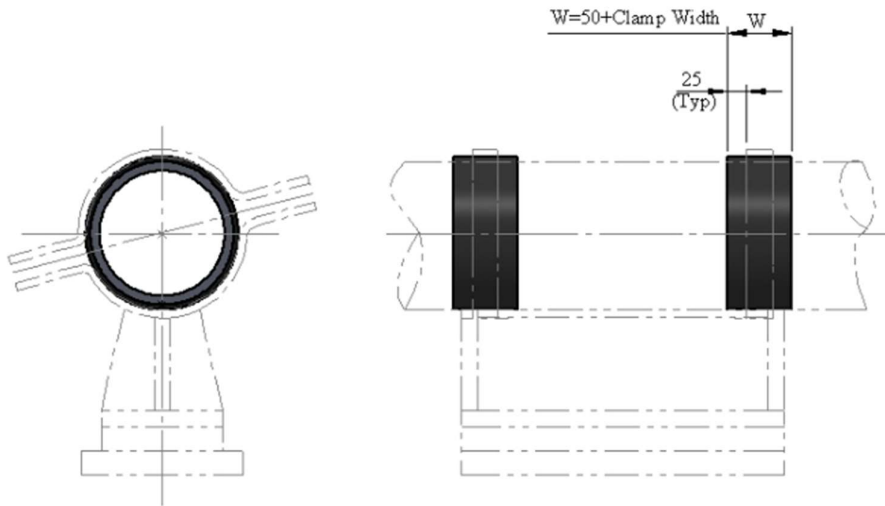
MI-011

* MI-011 SHALL ONLY BE USED FOR COLD SERVICE CLAMPED SHOES

Wrap around the pipe to make up 3mm thickness.

Design temperature range (-)100°C to (+) 150°C

No bonding required.

Low Temperature tape material and manufacturers shall be subject to project approval.

Clamp lining strip material: ASEplas SW712

7.12 LOW TEMPERATURE GRIP CLAMP LINING STRIP
 (-) 100 °c TO (+) 250 °c

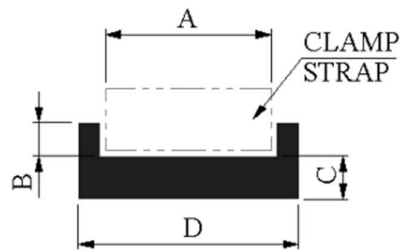
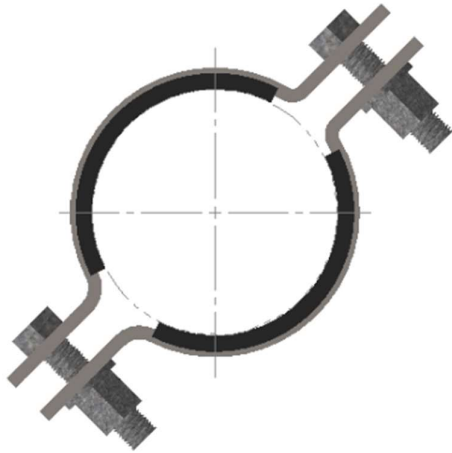
MI-012

TYPE	A	B	C	D
T-MI-012-000A	25	2	3	40
T-MI-012-000B	30	2	3	50
T-MI-012-000C	40	2	3	55
T-MI-012-000D	45	2	3	60
T-MI-012-000E	50	2	3	70
T-MI-012-000F	60	2	3	80
T-MI-012-000G	65	2	3	85
T-MI-012-000H	70	2	3	90
T-MI-012-000I	75	2	3	95
T-MI-012-000J	80	3	3	105
T-MI-012-000K	90	3	3	115
T-MI-012-000L	100	3	3	125
T-MI-012-000M	110	3	3	145
T-MI-012-000N	130	3	3	155
T-MI-012-000O	140	3	3	165
T-MI-012-000P	150	3	3	165
T-MI-012-000Q	200	3	3	215

Clamp Lining Strip Materials / Bonding from manufacturers shall be subject to project approval.
 Design Temperature range (-)100°c to (+) 250° c
 Clamp lining strip material: ASEplas SW712.

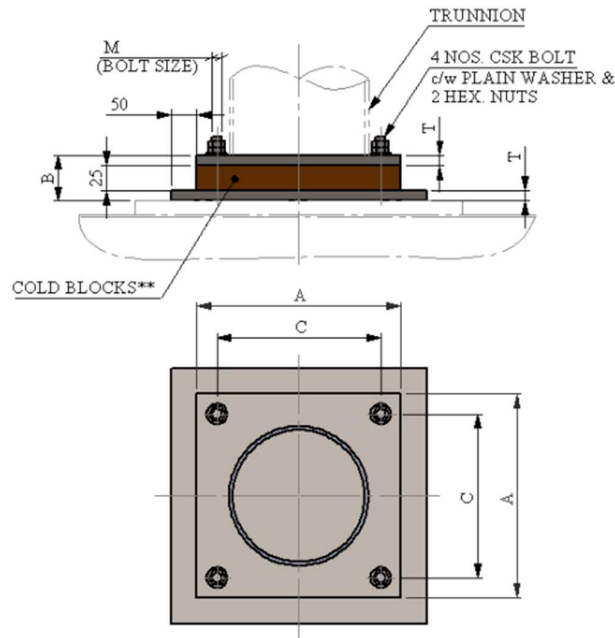
7.13 COLD BLOCK FOR VERTICAL TRUNNIONS
MI-020

TYPICAL PART NUMBER	AVAILABLE MATERIAL SHORT CODE	STD DETAIL TEMPERATURE LIMITATION	
		MAX. DESIGN TEMP	MIN. DESIGN TEMP
T- MI-020-(DN)-SS/CS (CS Bottom Plate)	SS / CS	+ 160 °C	(-) 196 °C
T-MI-020-(DN)-SS	SS	+ 160 °C	(-) 196 °C

TYPE	A	B	C	T	BOLT INFO		SAFE WORKING LOAD kN			MAX. TRUNNION DIAMETER	WEIGHTS (in kg)	
					SIZE M	No. Off	MAX. COMPRESSIVE	MAX. LIFTING	MAX. LATERAL		SS / CS	SS
T-MI-020-0080	150	55	100	15	M16 x 95	4	112	65	45	DN 80	10	10
T-MI-020-0100	200	55	140	15	M16 x 95	4	200	65	45	DN100	16	13.5
T-MI-020-0150	250	65	190	20	M16 x 105	4	310	65	45	DN 150	30	31
T-MI-020-0200	300	65	240	20	M16 x 105	4	450	65	45	DN 200	41	42
T-MI-020-0250	350	65	290	20	M16 x 105	4	610	65	45	DN 250	54	55
T-MI-020-0300	400	65	320	20	M20 x 110	4	800	100	70	DN 300	69	69
T-MI-020-0350	450	65	370	20	M20 x 110	4	1000	100	70	DN 350	85	85
T-MI-020-0400	500	65	420	20	M20 x 110	4	1250	100	70	DN 400	102	103
T-MI-020-0450	550	65	470	20	M20 x 110	4	1500	100	70	DN 450	122	123
T-MI-020-0500	600	65	520	20	M20 x 110	4	1800	100	70	DN 500	143	144
T-MI-020-0600	700	65	620	20	M20 x 110	4	2450	100	70	DN 600	191	192

All welds to be a= 0.7 x WT, but max 4mm CFW.

** Design Temperature range for Cold Block Material is (-)200°c to (+) 160° c Continuous.

Blocks must be supported Over at least 25% of Base.

Bolts to be according to ISO 10642 SS A4 80 (Full Threaded), & Nuts SS A4 80

Std. Type includes all bolts, plain washers and double nuts. Bolts to have a minimum overlength of 3 Threads.

Block material: ASEplas 2010 SWA.